

Calculation form gas spring applications

Company :
 Telephone :
 E-mail address :
 Contactperson :
 Project :

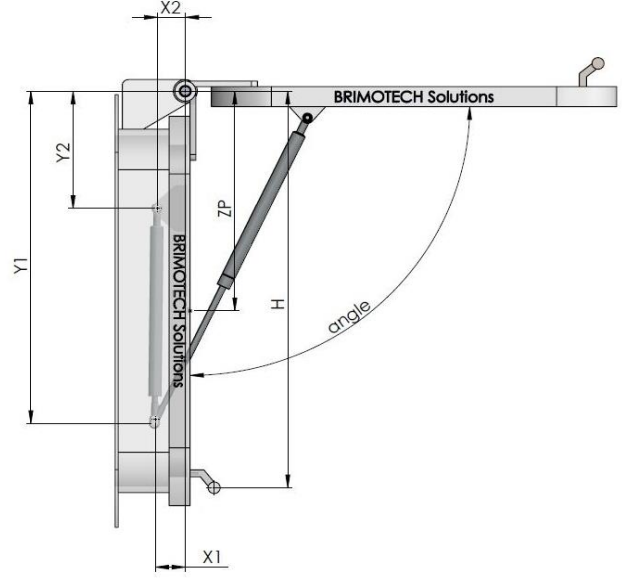

Koperstraat 4
 8211 AK Lelystad
 The Netherlands
 Tel: +31(0)320 769103 Fax: +31(0)84 8317577
 www.brimotech.nl
 info@brimotech.nl

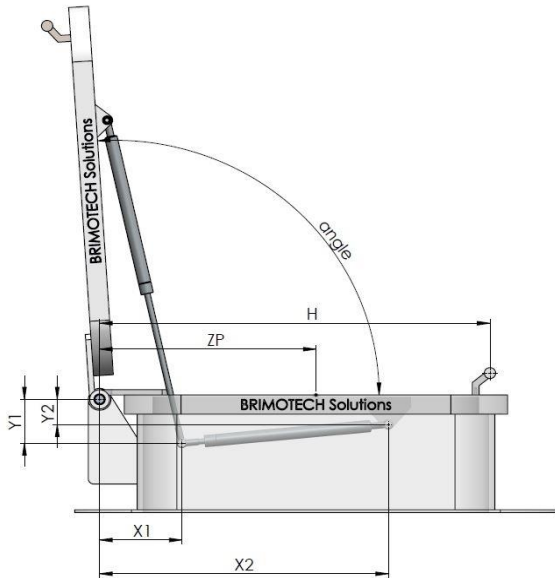

Situation **A**

B

Required information for calculation

Weight of lid : kg
 Distance center of mass (ZP) : mm
 Distance of lifting (H) : mm
 Required opening angle (Angle) : degree

Required material gas springs

Painted steel RAL9005 (Black)
 RAL9006 (Alu/white)

Stainless 316L Polished (standard)

Distances pivot points gas springs [mm]

X1 min. :	mm	X1 max. :	mm
X2 min. :	mm	X2 max. :	mm
Y1 min. :	mm	Y1 max. :	mm
Y2 min. :	mm	Y2 max. :	mm

Required end fittings (for more options, please contact Brimotech)



Remarks: